

Standard Construction and Materials

FRAME: .081" thick (nominal) extruded aluminum, 6063-T52/T6 alloy.

BLADE: .081" thick (nominal) extruded aluminum, 6063-T52/T6 alloy.
Blades approximately 3" on center.

LOUVER FACE: Full width sill, with blades and head contained in jambs.

SCREEN: (When indicated.)

1/2" flattened aluminum (.051" thick),

-or- 1/2" sq. mesh, intermediate double-crimped aluminum wire, .063" dia.,

-or- 18/16 mesh, .011" dia. aluminum wire, insect screen.

FINISH: Mill

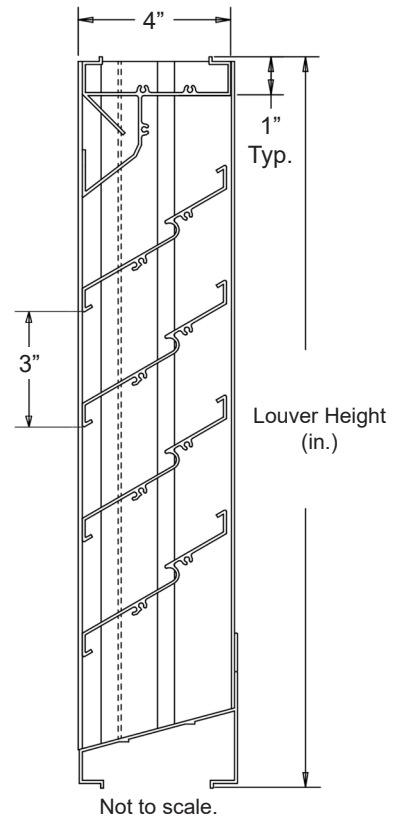

Options

Finish - Baked Enamel, Kynar, Anodize

Notes

- 1/2" nominal deduction will be made to the opening size given.
- Approximate shipping weight is 5.2 lbs./sq.ft.

Louver Sizes

Min Panel	Max Single Panel
12"W x 12"H	60"W x 96"H

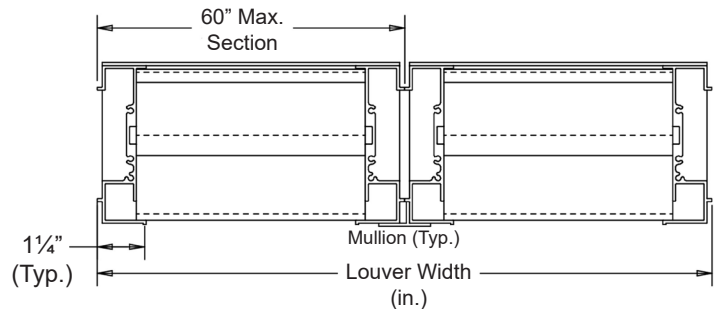
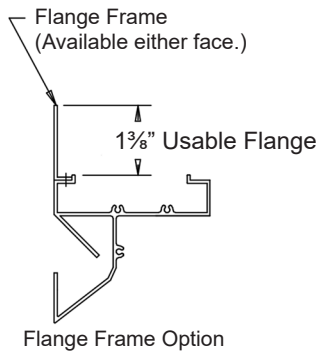

Item #	Qty	Width	Height	Width	Height	Mullion	Type	Location	Screens	Union Made
		Opening Size		Louver Size						
Arch. / Eng.:						EDR:		ECN:		Job:
Contractor:										
Project:						Date:		DWN:		DWG:

In the interest of product development, Cesco Products reserves the right to make changes without notice.



450 Riverside Dr • Wyalusing PA, 18853
Phone: 570-746-1888 • Fax: 570-746-9286
www.cescoproducts.com

Performance Data

Pressure Drop: .08 in. w.g. at 780 fpm (Intake)

Free Area: 7.66 sq.ft. = 47.9% for 48"W x 48"H sample tested in accordance with AMCA Standard 500-L.

Beginning Point of Water Penetration: 763 fpm

Ratings do not include effects of a screen.

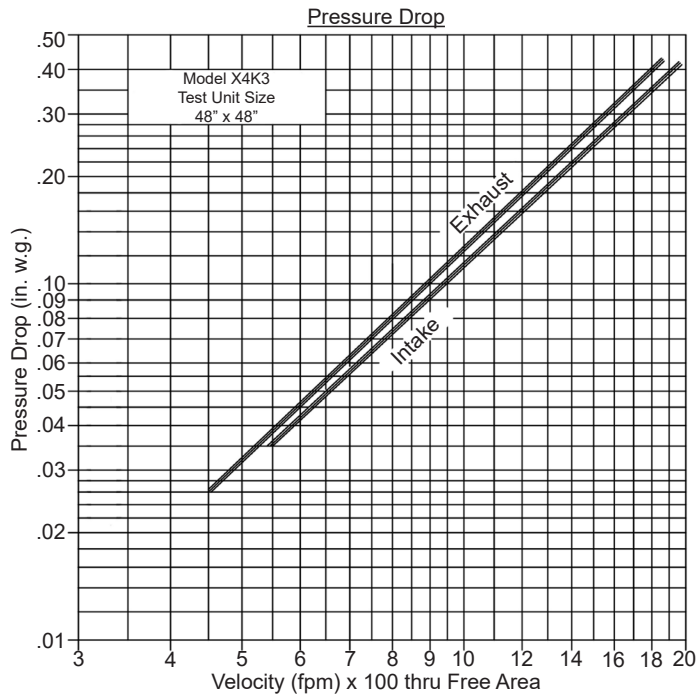

Intake air converted to standard air density.
Tested to AMCA Standard 500-L, Figure 5.5.

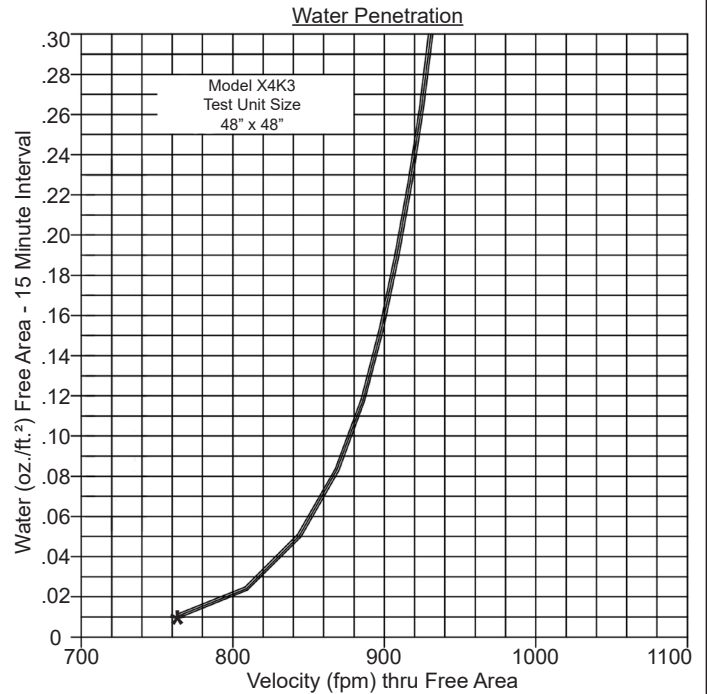

Free Area (sq.ft.)

		Width (in.)								
		12"	18"	24"	30"	36"	42"	48"	54"	60"
Height (in.)	12"	.32	.51	.71	.91	1.10	1.30	1.50	1.70	1.89
	24"	.74	1.21	1.68	2.15	2.62	3.08	3.55	4.02	4.49
	36"	1.17	1.91	2.65	3.39	4.13	4.87	5.61	6.35	7.08
	48"	1.60	2.61	3.62	4.63	5.64	6.65	7.66	8.67	9.68
	60"	2.03	3.31	4.59	5.87	7.15	8.43	9.71	10.99	12.28
	72"	2.46	4.01	5.56	7.11	8.66	10.22	11.77	13.32	14.87
	84"	2.89	4.71	6.53	8.35	10.18	12.00	13.82	15.64	17.47
	96"	3.32	5.41	7.50	9.60	11.69	13.78	15.88	17.97	20.06